

Blind rivet nuts for dampening vibration

RIVKLE® Elastic



The fastener with a metal threaded insert captured within a thermoplastic elastomer body, for assemblies subject to vibration.



BÖLLHOFF

The Principle

The RIVKLE® Elastic is an easily fitted fastener, where components subject to vibration are not only securely and tightly screwed together from one side of the workpiece, but at the same time oscillation is dampened, along with any vibratory noise. In addition, an electrically insulated screw fastening is created between two components.

The fastening consists of a metal threaded insert captured within a bearing component made of thermoplastic elastomer. The brass insert is coated in EPDM-X+PP. On installation, the RIVKLE® Elastic is inserted into a pilot hole drilled or pierced within the holding component. Clamping nodules beneath the external flange retain the fastener in its unset state, preventing loss during assembly. As the threaded portion of the female insert is at the base of the elastomer fastener, tightening a mating screw draws back the fastener to form a bead which bears against the blind side of the component.

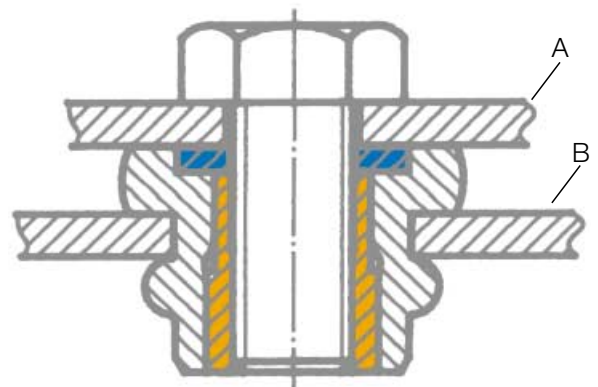

If component A is made of steel, with a pilot hole to DIN ISO 273, RIVKLE® Elastic without washer should be used. RIVKLE® Elastic with washer is preferred for components made of plastic, aluminium or steel with an oblong hole. A starting torque can be stipulated for the screw fastening according to the pressure resistance of the fastening component.

The Advantages:

- mounted from one side of the workpiece
- absorbs vibrations thereby reducing noise
- insulates against heat and electricity
- a force-locked screw fastening, producing screw security by means of appropriate starting torque

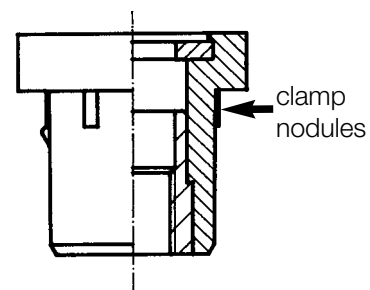

Technical Data

The starting torque MA is dependent on the component material and the quality of the screw. Axial load F should be tested for each application with all parameters being synchronised.

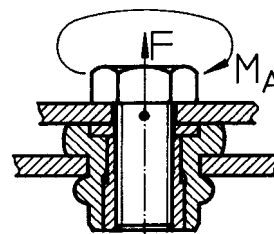

Resistance to thermal ageing* of an elastomer component (TPV)

Temperature °C	Ageing Time, days	100%-Module **		Tensile Strength on breaking**		Hardness Shore A *** 5 sec. Alteration
		Mpa Remainder	% Remainder	MPa Remainder	% Remainder	
125	41,7 (1,000 hrs)	2,4	104	6,8	113	+ 2

* Thermal ageing in hot air oven
 ** Stress/Strain ASTM D 412;
 % remainder = % retention of mechanical characteristics
 *** Hardness, ASTM D 2240

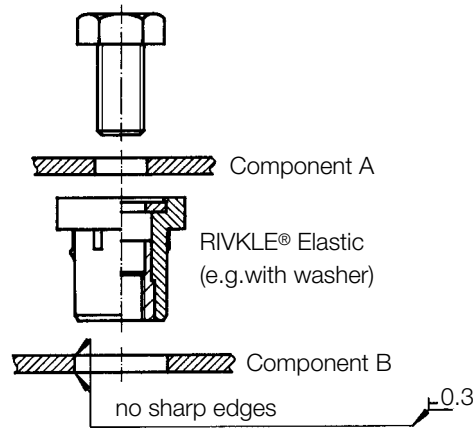

Technical Information / Data

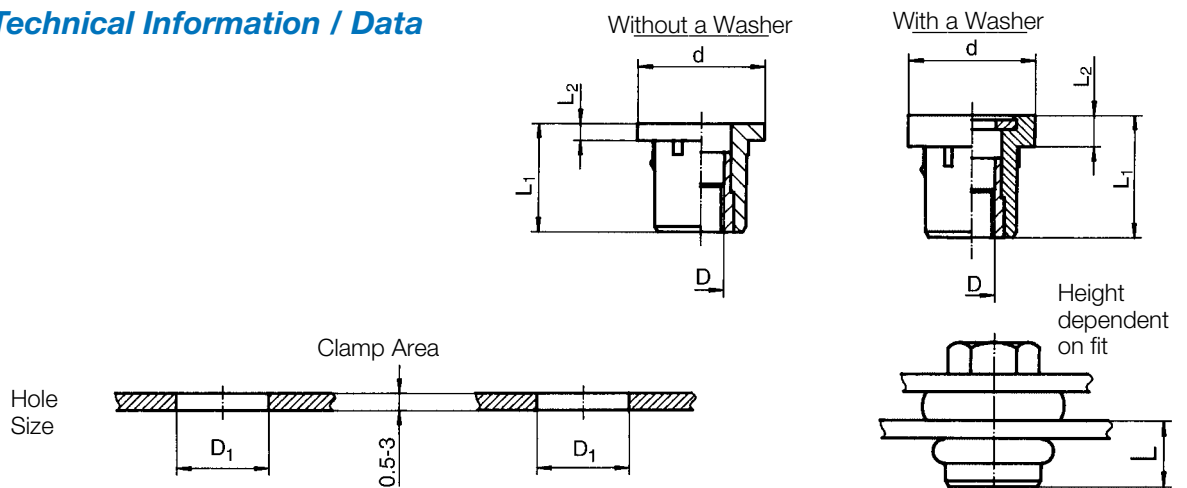

Product Code	Design	D	d	L1	L2	Hole Diameter D1	Set Length L
2430 004 0300*	without washer	M 4	15	15,5	1,5	10,3 + 0,2	9
2431 004 0300	with washer	M 4	15			10,3 + 0,2	9
2430 005 0300*	without washer	M 5	15	15,5	1,5	10,3 + 0,2	9
2431 005 0300	with washer	M 5	15	17,7	3,7	10,3 + 0,2	9
2430 006 0300*	without washer	M 6	18	17,0	2,0	13,0 + 0,2	10
2431 006 0300	with washer	M 6	18	19,3	4,3	13,0 + 0,2	10
2430 008 0300	without washer	M 8	22	19,0	3,0	16,0 + 0,2	11
2431 008 0300	with washer	M 8	22	21,6	5,6	16,0 + 0,2	11

* available on request

Applications

Automotive Industry

Fastening of filter housings, cover components etc.

General Industry

Fastening of fan motors, printed circuit boards for electrostatic partition, fixing of sensitive gauges, switch cabinets etc.

Example of application: carbon filter for cars

