

*Threaded inserts for plastics*

**AMTEC®**



**Precision threaded inserts**  
for plastic parts and equipment for installation

[www.boellhoff.com](http://www.boellhoff.com)

**BÖLLHOFF**



## AMTEC® heavy-duty threaded inserts for plastics

### Advantages of our threaded inserts:

Our threaded inserts are designed for after-moulding insertion, thereby dispensing with inlaying and injection moulding around threaded inserts; this means:

- Shorter injection cycles and an automatic injection moulding process with no inlaying of metal components
- No danger of injection mould damage by the metal parts moving during moulding
- No tension cracks owing to difficult control of shrinkage around the metal part
- Advantages versus self-tapping screws, since the joint can be separated as often as required without thread damage
- Safe, tension-free anchorage with high pull-out and torque values
- Reduction in manufacturing costs of the plastic components and increased quality of your products



### Our product range includes:

- **Precision threaded inserts** for heat and ultrasonic insertion, expansion anchoring and self-tapping insertion for moulded components in thermosets, thermoplastic or reactive resin materials (including filled or foamed materials).
- **Installation tools and machines**  
We offer you the most efficient installation method via the KVT system.
  - Manual installation tools
  - Semi-automatic installation tools
  - Automatic machines: ranging from multiple insertion for large production runs to freely programmable CNC-controlled installation machines for frequently changing components
- **Fastening components for direct screw-fitting of plastic parts with appropriate tools**
- **Customised development:** we develop and manufacture “tailor made” threaded inserts and installation devices for your specific requirements

## Examples of applications of AMTEC® threaded inserts

This selection of plastic components shows a small section of the wide range of possible applications for our threaded inserts in different plastics, in which optimum benefit is obtained from all the advantages for economical and reliable construction.

### What is the solution for your specific tasks?

Our technical advice service is available at all times without any commitment on your part for expert consultation and installation demonstrations.

Our own development and manufacturing departments offer product solutions tailored to specific applications.

Mobile telephone case  
**SONICSERT®** M1.6



Pump housing  
**HITSERT® 2** M5 and  
**SPREDSERT®** with  
retaining flange M6

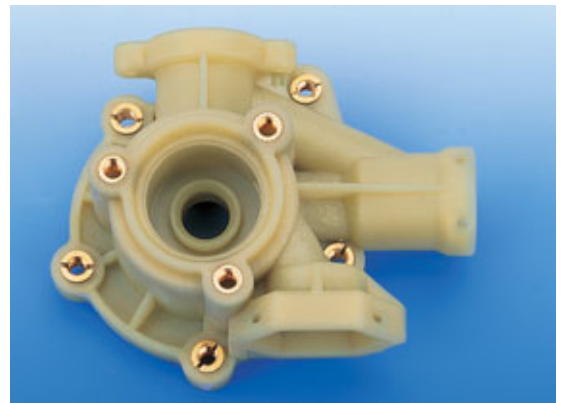

Furniture handle  
**HITSERT® 2** M4



Walking aid  
**HITSERT® 2** M8



Electronic switch box  
**EXPANSIONSERT 1**  
M4



Pump housing  
**HITSERT® 2** bolts M6  
and compression limiters



## AMTEC® at a glance

Qualifications	HITSERT® 2	HITSERT® 3	SONICSERT®	SONICSERT® SCREWLOCK®	QUICKSERT® QUICKSERT® Hex self-tapping	QUICKSERT® type 1230 expansion	EXPANSION- SERT 1	EXPANSION- SERT 2	SPREDSERT® type 1/ type 2 SPREDSERT® with retaining flange
Performance targets									
<b>Suitability for different parent materials</b>									
- Thermoplastics	very good	very good	very good	very good	good	good	satisfactory	in exceptional cases	type 1/with retaining flange good
- Thermosets	unsuitable	limited	unsuitable	unsuitable	very good	good	good	unsuitable	type 2/with retaining flange good
- Foam	unsuitable	no	unsuitable	unsuitable	satisfactory	limited	not quite so good	good	not quite so good
- Elastomers	unsuitable	no	unsuitable	unsuitable	satisfactory	no	unsuitable	good	not quite so good
Minimum equipment required for installation (machine technology)	thermal installation mach. (min. quantity. by soldering gun)	„Soldering gun“ screwdriver toggle press	ultrasonic welding machine	ultrasonic welding machine	manual fitting tool screwdriver	spindle lifting toll (possible press)	manual fitting mandrel	manual fitting mandrel	manual fitting mandrel
Recommended wall thickness (comparison index between types: 1 = small, 4 = large)	1	1	2	2	3	4	4	4	3
Preparation of component	blind or through hole	blind or through hole	blind or through hole	blind or through hole	blind or through hole	blind or through hole	blind hole	blind hole	blind or through hole
Influence of tolerance fluctuations in the drill hole. Catalogue recommendations 0.1 mm > S > 0.3 mm	strong	strong	strong	strong	weak	strong	very strong	weak	very strong
Interference fit values in thermoplastics	100 %	100 % for heat insertion and screwing, 70 % for pressing	80 %	80 %	120 %	100 %	60 %	-	50 %
Ability to be bolted from both sides	yes		yes	yes	yes		no	no	yes
<b>Special requirements:</b>									
- Density	with O-ring (performed)		with O-ring (conceivable)		no		no	no	no
- Threaded bolt	yes		possible with major expenditure		no		no	no	no
- Through hole	yes		conceivable (expend.)	conceivable (expend.)	no		no	no	no
<b>Miscellaneous</b>	by taper (8*) - selfcentring - low tension	variable seal insert introduction				also suitable for light alloys	simple installation		favourable price
<b>In this catalogue on page</b>	<b>7 – 8</b>	<b>9</b>	<b>10 – 11</b>	<b>12</b>	<b>14 – 16</b>	<b>23</b>	<b>17 – 18</b>	<b>19</b>	<b>20 – 22</b>

## Range overview for AMTEC® threaded inserts

### Thermal installation

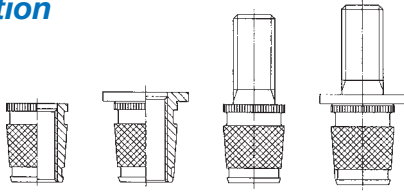

#### HITCERT® 2

Tapered threaded insert for all thermoplastics.  
Particularly suitable for thermal conduction installation.  
Rational installation by single-spindle, multiple spindle or automatic machines.

Brass M2 – M8 \*

Page 7 – 8

### Thermal installation, tapping and cold insertion



#### HITCERT® 3 universal use

Tapered threaded insert for thermoplastics.

Particularly suitable for

■ Thermal installation ■ Tapping ■ Cold insertion

Rational installation by single-spindle, multiple spindle or automatic machines.

Brass M3 – M8 \*

Page 9

### Ultrasonic installation

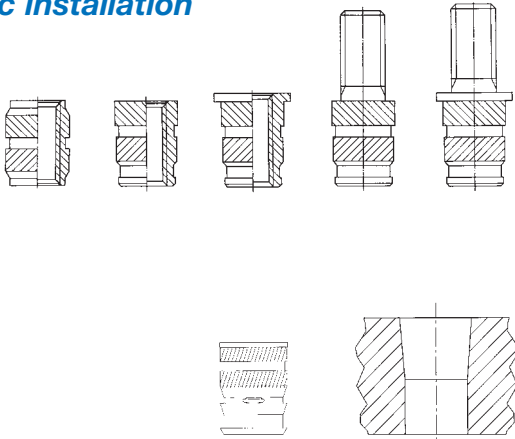

#### SONICSERT®

Threaded insert for all thermoplastics.

Particularly suitable for ultrasonic installation.

The ability to be fed from both sides is particularly suited to full automatic installation.

Brass M1.2 – M8 \*

Page 10 – 11

#### SONICSERT® SCREWLOCK®

The SONICSERT® SCREWLOCK® is a threaded insert with integrated screw gripping for subsequent thermal and ultrasonic installation in thermoplastics. The SONICSERT® SCREWLOCK® was designed specifically for applications in which vibrations occur or defined release torques are still required after multiple screwing.

Brass M2.5 – M6 \*

Page 12

### Ultrasonic welding, friction welding and thermal riveting



#### SNAPLOC® mini

is a mini snap element for use in thermoplastic components.

■ External and internal threads

■ Various thermoplastics available

Dimensions on request

Page 13

### Self-tapping installation

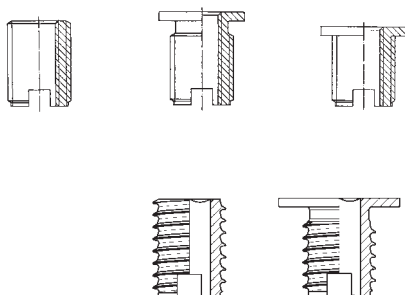

#### QUICKSERT®

Self-tapping threaded insert for brittle and ductile plastics, e.g. unsaturated polyester resins (SMC, injection moulding of glass fibre reinforced plastic), polyethane and glass fibre reinforced thermoplastics. Heavy duty, universally usable, optimum installation properties.

Steel/brass M4 – M10 \*

Page 14 – 15

#### QUICKSERT® Hex

Self-tapping threaded insert with hexagon socket and extra small thread angle for plastics. Suitable for thermoplastics and thermosets.

Brass M4 – M8 \*

Page 16

## Range overview for AMTEC® threaded inserts

### Expansion anchoring

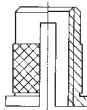
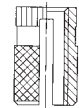
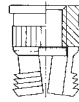
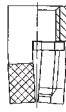

#### EXPANSIONSERT 1

Threaded insert for all plastics and their composite materials.

Brass M2.5 – M8 \*

Page 17 – 18

#### EXPANSIONSERT 2

Threaded insert for reactive resin, PUR, integral hard foam, elastomers and also wood composite materials.

Brass M2.5 – M8 \*

Page 19

#### SPREDSERT® 1

Threaded insert for all thermoplasts and their composite materials. Additional vibration-proof locking screw.

Brass M2 – M8 \*

Page 20

#### SPREDSERT® 2

Threaded insert for all thermosets. Additional vibration-proof locking screw.

Brass M3 – M6 \*

Page 21

#### SPREDSERT® with retaining flange

Threaded insert for through holes in all plastics with high pull-out values.

Brass M3 – M6 \*

Page 22

#### QUICKSERT® type 1230

Threaded insert for chipping-free installation in smooth location holes. Creates a stable thread in light alloy thermoplastic and thermoset materials.

Steel/brass M3 – M8 \*

Page 23

### Installation tools and machines

for all our threaded inserts our KVT system offers you the most efficient installation method for your batch size. Manual installation tools, semi-automatic installation tools, automatic machines: ranging from multiple insertion for large production runs to freely programmable CNC-controlled installation machines for frequently changing components.

Page 26–30

### Extended range for direct screw-fitting for plastics with screw driving systems

Page 31

\* Other dimensions and materials on request.

**HITSERT® 2**



**Advantages**

- Ideal for thermoplastic components
- Specifically designed for thermal installation
- Distortion-proof and low-stress anchorage
- High pull-out values
- Economical installation by single-spindle, multiple spindle or automatic machines with preheating devices

Material: Cu Zn 38 Pb 2

**Principle**



The **HITSERT® 2** threaded insert is heated to the melt temperature of the plastic. The surrounding material is briefly plasticised by thermal conduction on insertion and flows into the undercut of the threaded insert. A low-stress interference fit results on cooling.

Type 0932

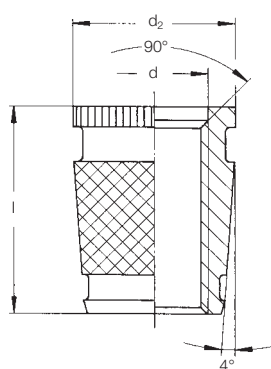

Type 0931®

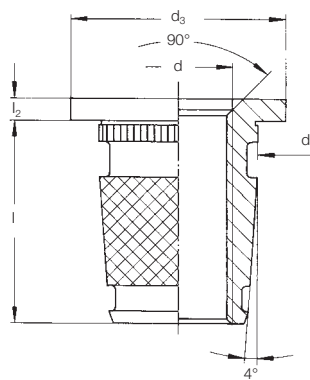

Location hole®

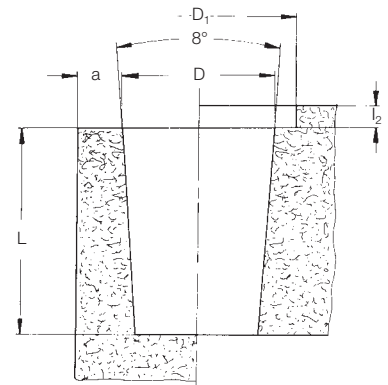

For installation tools and machines, please refer to pages 26–30

d	Type 0932 Article no	Type 0931® Article no	l	l <sub>2</sub>	d <sub>2</sub>	d <sub>3</sub>	D <sup>+0.1</sup>	D <sub>1</sub>	L <sub>min.</sub>	a <sub>min.</sub>
M 2	0932 102 0005	0931 102 0056	5.0	0.6	4.1	5.0	3.8	5.2	6.0	1.5
M 2.5	0932 125 0005	0931 125 0056	5.0	0.6	4.1	6.0	3.8	6.2	6.0	1.5
M 3	0932 103 0005	–	5.0	–	4.7	–	4.4	6.2	6.0	1.8
M 3	0932 103 0055	0931 103 0061	5.5	0.6	4.7	6.0	4.4	6.2	6.5	1.8
M 3.5	0932 135 0006	0931 135 0068	6.0	0.8	5.5	7.0	5.2	7.2	7.0	1.8
M 4	0932 104 0006	–	6.0	–	5.9	–	5.8	8.2	7.0	2.0
M 4	0932 104 0075	0931 104 0083	7.5	0.8	5.9	8.0	5.8	8.2	8.5	2.0
M 5	0932 105 0007	–	7.0	–	7.0	–	6.9	8.7	8.0	2.0
M 5	0932 105 0009	0931 105 0010	9.0	1.0	7.0	8.5	6.9	8.7	10.0	2.5
M 6	0932 106 0009	–	9.0	–	8.6	–	8.5	10.2	10.0	2.5
M 6	0932 106 0010	0931 106 0011	10.0	1.0	8.6	10.0	8.5	10.2	11.0	2.5
M 8	0932 108 0012	0931 108 0013	12.0	1.0	11.1	12.0	10.9	12.2	13.0	3.0

Metric ISO threads to DIN 13-6H.  
All rights reserved for technical modifications.

® Guide values: dependent on component material. Alter after insertion tests, if necessary.  
® The flange offers a wide support area, thereby reducing surface pressure.  
Minimum quantity on request.

Other sizes, specials and materials on request.

Type 0940

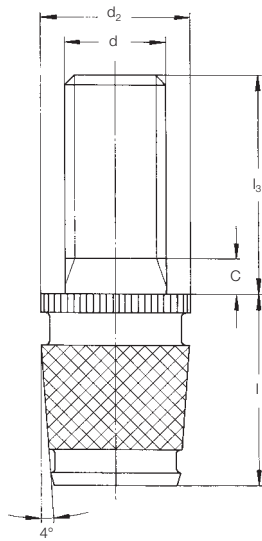

Type 0941<sup>④</sup>

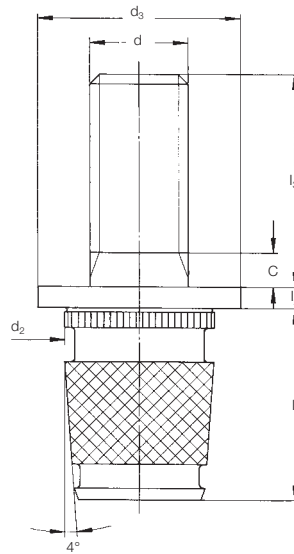

Location hole<sup>①</sup>

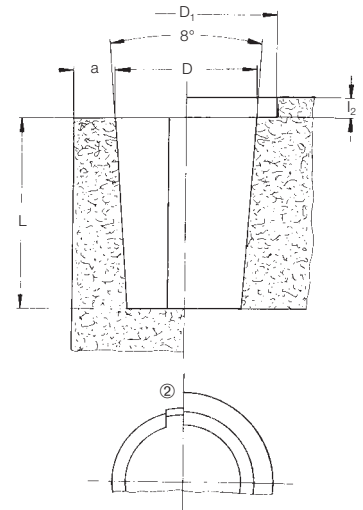

For installation tools and machines, please refer to pages 26–30

d	Type 0940 <sup>⑤</sup> Article no	Type 0941 <sup>⑤</sup> Article no	l	l <sub>3</sub>	l <sub>2</sub>	d <sub>2</sub>	d <sub>3</sub>	D <sup>+0.1</sup>	D <sub>1</sub>	L <sub>min.</sub>	a <sub>min.</sub>
M 2.5	0940 125 0005	0941 125 0005	5.0	5.0	0.6	4.1	6.0	3.8	6.2	6.0	1.5
	0940 125 0010	0941 125 0010	5.0	10.0	0.6	4.1	6.0	3.8	6.2	6.0	1.5
M 3	0940 103 0005	0941 103 0005	5.5	5.0	0.6	4.7	6.0	4.4	6.2	6.5	1.8
	0940 103 0010	0941 103 0010	5.5	10.0	0.6	4.7	6.0	4.4	6.2	6.5	1.8
M 3.5	0940 103 0015	0941 103 0015	5.5	15.0	0.6	4.7	6.0	4.4	6.2	6.5	1.8
	0940 135 0005	0941 135 0005	6.0	5.0	0.8	5.5	7.0	5.2	7.2	7.0	1.8
	0940 135 0010	0941 135 0010	6.0	10.0	0.8	5.5	7.0	5.2	7.2	7.0	1.8
M 4	0940 135 0015	0941 135 0015	6.0	15.0	0.8	5.5	7.0	5.2	7.2	7.0	1.8
	0940 104 0005	0941 104 0005	7.5	5.0	0.8	5.9	8.0	5.8	8.2	8.5	2.0
	0940 104 0010	0941 104 0010	7.5	10.0	0.8	5.9	8.0	5.8	8.2	8.5	2.0
M 5	0940 104 0015	0941 104 0015	7.5	15.0	0.8	5.9	8.0	5.8	8.2	8.5	2.0
	0940 105 0010	0941 105 0010	9.0	10.0	1.0	7.0	8.5	6.9	8.7	10.0	2.0
	0940 105 0015	0941 105 0015	9.0	15.0	1.0	7.0	8.5	6.9	8.7	10.0	2.0
M 6	0940 105 0025	0941 105 0025	9.0	25.0	1.0	7.0	8.5	6.9	8.7	10.0	2.0
	0940 106 0010	0941 106 0010	10.0	10.0	1.0	8.6	10.0	8.5	10.2	11.0	2.5
	0940 106 0015	0941 106 0015	10.0	15.0	1.0	8.6	10.0	8.5	10.2	11.0	2.5
	0940 106 0025	0941 106 0025	10.0	25.0	1.0	8.6	10.0	8.5	10.2	11.0	2.5

Metric ISO threads to DIN 13-6H.  
All rights reserved for technical modifications.

<sup>①</sup> Guide values: dependent on component material. Alter after insertion tests, if necessary.

<sup>②</sup> For blind holes, we recommend core pins with ventilation features.

Further details on request.

<sup>③</sup> Minimum quantity on request.

<sup>④</sup> The flange offers a wide support area, thereby reducing surface pressure.

Other sizes, specials and materials on request.

## HITSERT® 3



### Advantages

- Tried and trusted 8° taper angle
- Self-centring
- Wide contact area before insertion
- Flexible installation by thermal insertion, self tapping or cold insertion
- Short insertion times
- Milled external contour (low tolerances)
- Sealing inserts available

### Principle

The **HITSERT® 3** is a tapered universal insert for thermoplastics (thermal installation, self tapping and cold insertion).

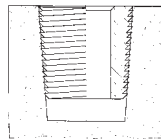

Owing to its patented external contour (characterised by a fine, self-tapping thread with an asymmetrical side profile) the **HITSERT® 3** provides a threaded insert that enables the user to employ for the first time the complete range of tried and trusted insertion methods.

Our application technology assists you in finding the optimum manufacturing method for your specific application (expenditure in terms of installation, tightening values, etc. You establish the priorities).

#### Type 0935

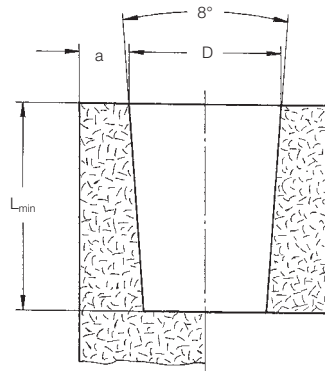
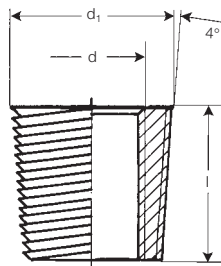

Thread size	Article no	$d_1^{\pm}$	l	$D^{+0.1^*}$ (mm)	$L_{min.}$	$a_{min.}$
•M 2	0935 1020 004	4.1	4	3.8	5.0	1.5
•M 2.5	0935 1250 004	4.1	4	3.8	5.0	1.5
M 3	0935 1030 005	4.7	5	4.4	6.0	1.8
M 4	0935 1040 075	6.1	7.5	5.8	8.5	2.0
M 5	0935 1050 009	7.3	9	6.9	10.0	2.0
M 6	0935 1060 010	8.9	10	8.5	11.0	2.5
•M 8	0935 1080 012	11.3	12	10.9	13.0	3.0

• Threaded inserts with flanges and specials on request.

\* Guide values: dependent on component material. Alter after insertion tests, if necessary.  
Minimum quantity on request.

German and international patents applied for and granted.

**SONICSERT®**



**Advantages**

- Suitable for thermoplastic components
  - Specifically designed for ultrasonic installation
  - Distortion-proof and low-stress anchorage
  - High pull-out values
  - Type 0730 can be fed from both sides.
- Advantages for automatic feed, since no directional orientation required.

Material: Cu Zn 38 Pb 2

**Principle**

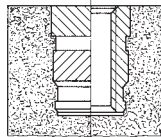

The **SONICSERT®** threaded insert is installed using commercially available ultrasonic vibration devices. The surrounding material in the welding area is plasticised by the ultrasound vibrations and flows into the undercuts of the threaded insert. A low-stress interference fit results on cooling.

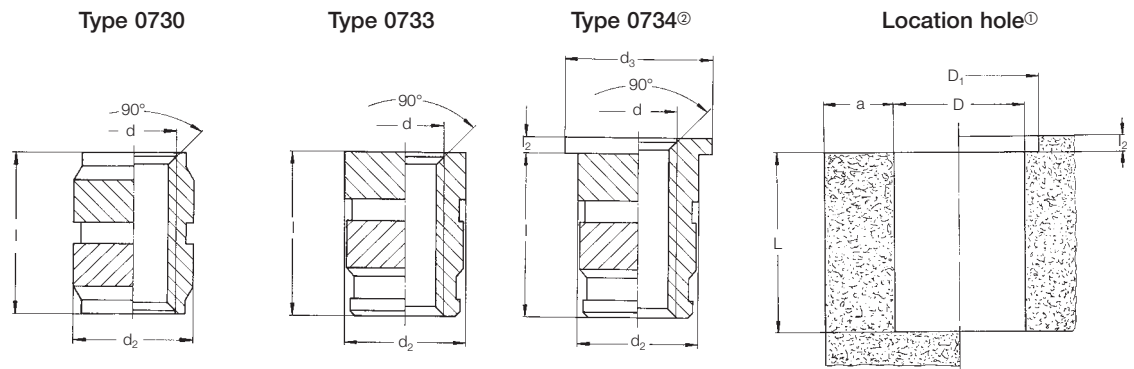

For installation tools and machines, please refer to pages 26–30

d	Type 0730 Article no	Type 0733 Article no	Type 0734® Article no	l	l <sub>2</sub>	d <sub>2</sub>	d <sub>3</sub>	D <sup>+0.1</sup>	D <sub>1</sub>	L <sub>min.</sub>	a <sub>min.</sub>
M 1.2	–	–	0734 112 0290	2.9	0.4	2.0	2.6	1.6	2.8	3.3	0.65
M 1.4	0730 114 0002	–	–	2.0	–	2.2	–	1.9	–	2.5	0.7
M 1.4	–	–	0734 114 0310	3.1	0.4	2.2	2.8	1.8	3	3.5	0.7
M 1.6	0730 116 0250	–	–	2.5	–	3.0	–	2.6	–	3.0	0.8
M 1.6	–	–	0734 116 0330	3.3	0.4	2.5	2.9	2.1	3.1	3.7	0.8
M 2	0730 102 0004	0733 102 0004	0734 102 0046	4.0	0.6	3.6	5.0	3.2	5.2	4.5	2.0
M 2.5	0730 125 0058	0733 125 0058	0734 125 0064	5.8	0.6	4.6	6.0	4.0	6.2	6.5	2.3
M 3	0730 103 0058	0733 103 0058	0734 103 0064	5.8	0.6	4.6	6.0	4.0	6.2	6.5	2.3
M 3.5	0730 135 0072	0733 135 0072	0734 135 0008	7.2	0.8	5.4	7.0	4.8	7.2	8.0	2.5
M 4	–	0733 104 0072	–	7.2	–	6.3	–	5.6	8.2	8.0	2.5
M 4	0730 104 0082	0733 104 0082	0734 104 0009	8.2	0.8	6.3	8.0	5.6	8.2	9.0	2.5
M 5	–	0733 105 0082	–	8.2	–	7.0	–	6.4	8.7	9.0	2.7
M 5	0730 105 0095	0733 105 0095	0734 105 0105	9.5	1.0	7.0	8.5	6.4	8.7	10.5	2.7
M 6	–	0733 106 0095	–	9.5	–	8.6	–	8.0	10.2	10.5	3.0
M 6	0730 106 0127	0733 106 0127	0734 106 0137	12.7	1.0	8.6	10.0	8.0	10.2	14.0	3.0
M 8	0730 108 0127	0733 108 0127	0734 108 0137	12.7	1.0	10.2	12.0	9.6	12.2	14.0	3.5

Metric ISO threads to DIN 13-6H.  
All rights reserved for technical modifications.

Other sizes, specials and materials on request.

® Guide values: dependent on component material. Alter after insertion tests, if necessary.

® The flange offers a wide support area, thereby reducing surface pressure.  
Minimum quantity on request.

Type 0743

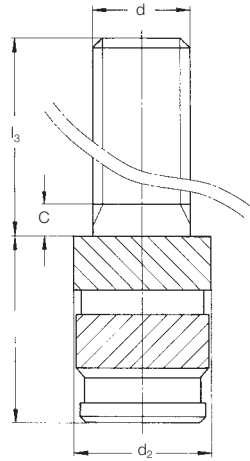

Type 0744®

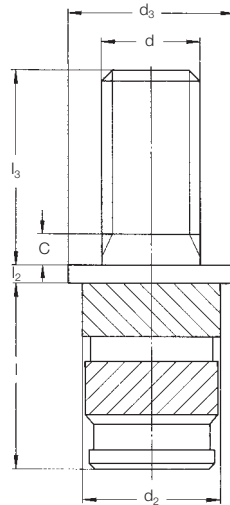

Location hole®

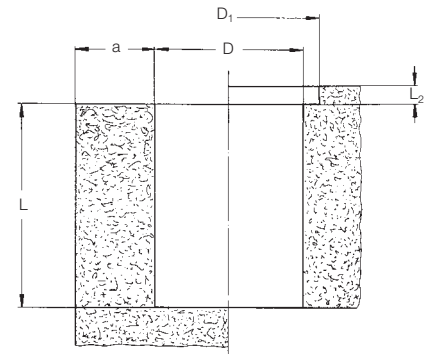

$C_{max} = 3P$

For installation tools and machines, please refer to pages 26–30

d	Type 0743® Article no	Type 0744® Article no	l	l <sub>2</sub> /L <sub>2</sub>	l <sub>3</sub>	d <sub>2</sub>	d <sub>3</sub>	D <sup>+0.1</sup>	D <sub>1</sub>	L <sub>min</sub>	a <sub>min</sub>
M 2	0743 102 0005	0744 102 0005	4.0	0.6	5.0	3.6	5.0	3.2	5.2	4.5	2.0
	0743 102 0010	0744 102 0010	4.0	0.6	10.0	3.6	5.0	3.2	5.2	4.5	2.0
M 2.5	0743 125 0005	0744 125 0005	4.0	0.6	5.0	3.6	5.0	3.2	5.2	4.5	2.0
	0743 125 0010	0744 125 0010	5.8	0.6	10.0	4.6	6.0	4.0	6.2	6.5	2.3
M 3	0743 103 0005	0744 103 0005	5.8	0.6	5.0	4.6	6.0	4.0	6.2	6.5	2.3
	0743 103 0010	0744 103 0010	5.8	0.6	10.0	4.6	6.0	4.0	6.2	6.5	2.3
	0743 103 0015	0744 103 0015	5.8	0.6	15.0	4.6	6.0	4.0	6.2	6.5	2.3
M 3.5	0743 135 0005	0744 135 0005	7.2	0.8	5.0	5.4	7.0	4.8	7.2	8.0	2.5
	0743 135 0010	0744 135 0010	7.2	0.8	10.0	5.4	7.0	4.8	7.2	8.0	2.5
	0743 135 0015	0744 135 0015	7.2	0.8	15.0	5.4	7.0	4.8	7.2	8.0	2.5
M 4	0743 104 0005	0744 104 0005	8.2	0.8	5.0	6.3	8.0	5.6	8.2	9.0	2.5
	0743 104 0010	0744 104 0010	8.2	0.8	10.0	6.3	8.0	5.6	8.2	9.0	2.5
	0743 104 0015	0744 104 0015	8.2	0.8	15.0	6.3	8.0	5.6	8.2	9.0	2.5
M 5	0743 105 0010	0744 105 0010	9.5	1.0	10.0	7.0	8.5	6.4	8.7	10.5	2.7
	0743 105 0015	0744 105 0015	9.5	1.0	15.0	7.0	8.5	6.4	8.7	10.5	2.7
	0743 105 0025	0744 105 0025	9.5	1.0	25.0	7.0	8.5	6.4	8.7	10.5	2.7
M 6	0743 106 0010	0744 106 0010	12.7	1.0	10.0	8.6	10.0	8.0	10.2	14.0	3.0
	0743 106 0015	0744 106 0015	12.7	1.0	15.0	8.6	10.0	8.0	10.2	14.0	3.0
	0743 106 0025	0744 106 0025	12.7	1.0	25.0	8.6	10.0	8.0	10.2	14.0	3.0
M 8	0743 108 0010	0744 108 0010	12.7	1.0	10.0	10.0	12.0	9.6	12.2	14.0	3.5
	0743 108 0015	0744 108 0015	12.7	1.0	15.0	10.0	12.0	9.6	12.2	14.0	3.5
	0743 108 0025	0744 108 0025	12.7	1.0	25.0	10.0	12.0	9.6	12.2	14.0	3.5

Metric ISO threads to DIN 13-6H.  
All rights reserved for technical modifications.

® Guide values: dependent on component material. Alter after insertion tests, if necessary.  
® Minimum quantity on request.  
® The flange offers a wide support area, thereby reducing surface pressure.

Other sizes, specials and materials on request.

**SONICSERT® SCREWLOCK® type**

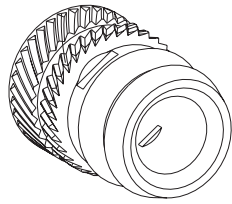

The SONICSERT® SCREWLOCK® is a threaded insert with integrated screw gripping for subsequent thermal and ultrasonic insertion in thermoplastics. The SONICSERT® SCREWLOCK® was designed specifically for applications in which vibrations occur or defined release torques are still required after multiple screwing. The desired screw gripping is achieved by **deliberate** deformation of the female thread. The results for repeated screwing are comparable with the recommendations to DIN 267 part 15 or ISO 2320.

**Comparison of screw locking methods**

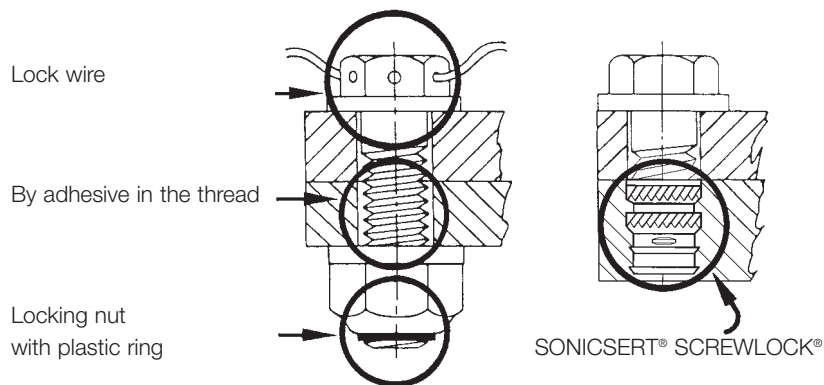

**Advantages and examples of applications of the SONICSERT® SCREWLOCK®**

- Economical, since single element
- Tried and trusted installation possibilities (thermal/ultrasonic insertion)
- Gripping torques similar to DIN 267 part 15 or ISO 2320 recommendations

- Examples of applications:
- Loudspeaker attachment
  - High pressure cleaners
  - Spray heads
  - Adjustment screws

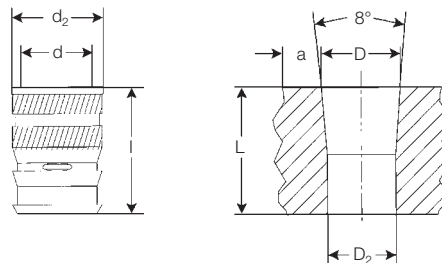

Thread size	Article no	d	l	*D <sup>+0,1</sup> 8°Be	D <sub>2</sub> <sup>+0,1</sup>	a <sub>min.</sub>	L <sub>min.</sub>
M 2.5	0937 125 0056	4.4	5.6	4.0	3.6	2.4	6.6
M 3	0937 103 0064	5.6	6.4	5.2	4.7	3.0	7.4
M 3.5	0937 135 0064	5.6	6.4	5.2	4.7	3.0	7.4
M 4	0937 104 0079	6.4	7.9	6.0	5.3	3.4	8.9
M 5	0937 105 0111	8.3	11.1	8.0	7.1	4.4	12.1
M 6	0937 106 0127	9.5	12.7	9.2	8.1	5.0	13.7

\* Guide values: dependent on component material. Alter after insertion tests, if necessary. Minimum quantity on request.

## Ultrasonic welding, friction welding and thermal riveting **SNAPLOC® mini**

### SNAPLOC® mini

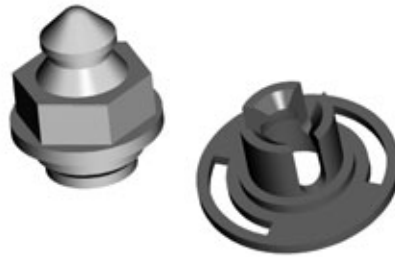

### Advantages

- Material bonded or form-fit connection
- Quick installation
- Thin-walled centring guides instead of thick-walled domes ensure no sink marks on thin-walled components
- Facilitates designs suitable for recycling
- Ideal for snap elements

### Principle

Depending on the requirement, material bonded or form-fit connections are made on thin-walled thermoplastic plastic casings.

Once the component is removed from the mould, the plastic inserts are joined using friction welding, ultrasonic welding or two-phase thermal riveting. The primary or functional area can be designed in different ways. (Snap fasteners, internal threads, external threads ...)

### Example



Half shell casing with SNAPLOC® mini, snap fastener design.

Before the joining process  
(friction welding)



After the joining process

Before the joining process  
(thermal riveting)



After the joining process

**QUICKSERT®**  
self-tapping threaded insert



**Advantages**

- For brittle and ductile plastics, e.g. unsaturated polyester resins (SMC, injection moulding of glass fibre reinforced plastic), polyurethane and glass fibre reinforced thermoplasts
  - Universally usable
  - Heavy-duty and torsion-proof thread
  - Optimum installation properties
- Material: 9 SMnPb 28 K, zinc-plated, chromated or Cu Zn 38 Pb 2

**Principle**

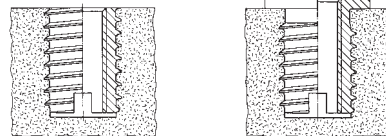

The **QUICKSERT®** consists of a cylindrical body with a female thread and a special outer thread. The outer thread profile features an extremely low angle and increases asymmetrically to the root of the thread. Installation with a low screwing torque is therefore optimised. With an ideal distribution of load, a high performance fixing is achieved. The insert has a cutting slot across the base. A version with a flange is available for special requirements. The threaded insert is inserted by self-tapping using a rotating spindle.

Type 1434

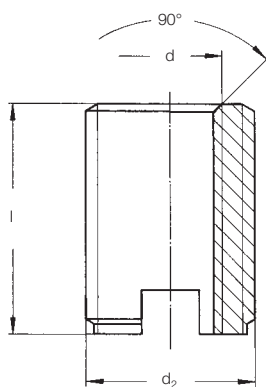

Location hole<sup>①</sup>

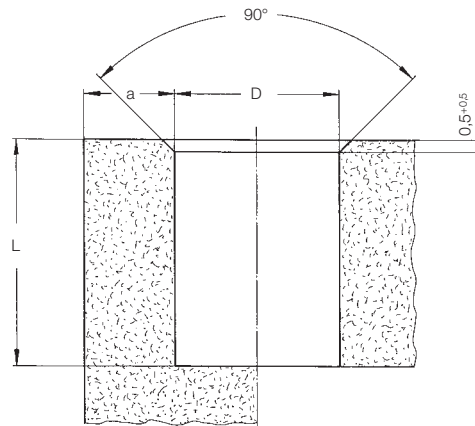

For installation tools and machines, please refer to pages 26–30

d	Steel, unhardened Article no	Brass Article no	l	d <sub>2</sub>	D <sup>②</sup>	L <sub>min.</sub>	a <sub>min.</sub>
M 3	1434 103 0006	1434 503 0006	6.0	6.0	4.6–5.4	7.0	2.0
M 4	1434 104 0008	1434 504 0008	8.0	7.0	5.6–6.6	9.0	3.0
M 5	1434 105 0010	1434 505 0010	10.0	8.0	6.6–7.6	11.0	4.0
M 6	1434 106 0014	1434 506 0014	14.0	10.0	8.1–9.4	15.0	4.0
M 8	1434 108 0015	1434 508 0015	15.0	12.0	10.1–11.4	16.0	5.0
M 10 <sup>③</sup>	1434 110 0018	1434 510 0018	18.0	14.0	12.1–13.4	19.0	5.0

Metric ISO threads to DIN 13-6H.  
All rights reserved for technical modifications.

① Guide values: dependent on component material. Alter after insertion tests, if necessary.

② Minimum quantity on request.

③ Hardened on request.

\* yellow chromated = unhardened, white chromated = hardened

Other dimensions and specials on request.

International patents applied for and granted.

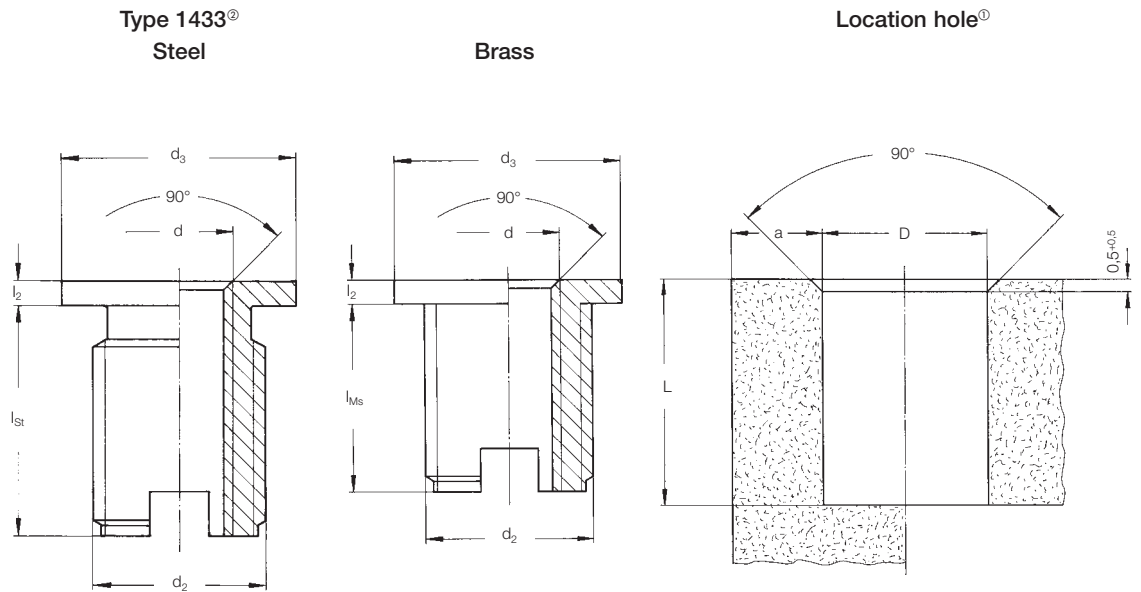

Recommended locating holes -D- for **QUICKSERT®** in various materials®

	M3	M4	M5	M6	M8	M10
PE (soft)	4.6	5.6	6.6	8.1	10.1	12.1
PP						
PA 6						
PA 6.6						
PBT						
PE (hard)	4.8	5.8	6.8	8.3	10.3	12.3
PET						
POM						
ASA						
SAN	5.0	6.0	7.0	8.5	10.5	12.5
ABS						
PA 6 GF 30%						
PBT GF 30%						
PET GF 30%						
PS						
PVC (hard)						
PA 6.6 GF 30%						
PC and PC + GF 30%	5.4	6.4	7.4	9.0	11.0	13.0
PPO/PPS GF 30%						
SMC						
ZMC		6.6	7.6	9.4	11.4	13.4
BMT						

Hexagonal flange version on request

For installation tools and machines, please refer to pages 26–30

d	Steel, unhardened Article no	Brass Article no	$l_{St}$	$l_{Ms}$	$l_2$	$d_2$	$d_3$	$D^{\circ}$	$L_{min. St}$	$L_{min. Ms}$	$a_{min.}$
M 4	1433 104 0105	1433 504 0009	9.5	8.0	1.0	7.0	10.0	5.6–6.6	10.5	9.0	3.0
M 5	1433 105 0127	1433 505 0112	11.5	10.0	1.2	8.0	11.0	6.6–7.6	12.5	11.0	4.0
M 6	1433 106 0174	1433 506 0154	16.0	14.0	1.4	10.0	13.0	8.1–9.4	17.0	15.0	4.0
M 8	1433 108 0184	1433 508 0164	17.0	15.0	1.4	12.0	15.0	10.1–11.4	18.0	16.0	5.0

Metric ISO threads to DIN 13-6H.  
All rights reserved for technical modifications.

® Guide values: dependent on component material. Alter after insertion tests, if necessary.  
® The flange offers a wide support area, thereby reducing surface pressure.  
® Hardened on request.

Other dimensions and specials on request.  
Minimum quantity on request.

International patents applied for and granted.

**QUICKSERT® Hex**  
self-tapping threaded insert



**Advantages**

- Efficient assembly thanks to driver shape (e.g. hexagonal drive pin).
- For thermoplastics and thermosets.
- Extra small pitch angle on the special outer thread reduces radial stressing.
- High pull out load and torsion-resistant thread.
- Special version with left-hand outer thread for high reverse lock safety.

**Principle**

The **QUICKSERT® Hex** consists of a cylindrical body with an internal thread, a hexagonal driving bore and a special outer thread. The outer thread profile has an extremely low pitch angle which increases asymmetrically towards the root of the thread. This enables installation with a low screwing torque. With an ideal distribution of load the insert will provide a high-performance fastening. The insert has a cutting slot across the base. A flanged version is available for special applications. The threaded insert is self-tapping and is inserted using a rotating spindle.

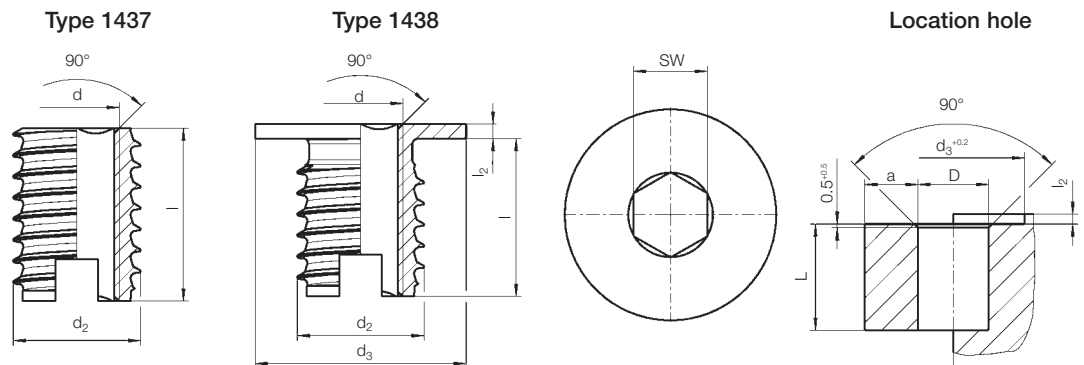

d	Brass, standard Article no	Brass, flange Article no	l	l <sub>2</sub>	d <sub>2</sub>	d <sub>3</sub>	L <sub>min.</sub>	a5 pt	SW
M 4	1437 504 0008	1438 504 0009	8.0	1.0	7.0	10.0	9.0	3.0	3.2
M 5	1437 505 0010	1438 505 0112	10.0	1.2	8.0	11.0	11.0	4.0	4.0
M 6	1437 506 0014	1438 506 0154	14.0	1.4	10.0	13.0	15.0	4.0	5.0
M 8	1437 508 0015	1438 508 0164	15.0	1.4	12.0	15.0	16.0	5.0	7.0

Minimum quantity on request.

For recommended location holes -D- for **QUICKSERT® Hex** in various materials® see table on page 14!

## EXPANSIONCERT 1



## Advantages

- Universal threaded insert for thermoset and thermoplastic components
- Heavy-duty thread by expansion anchoring
- Rapid, economical installation

Material: Cu Zn 38 Pb 2

## Principle

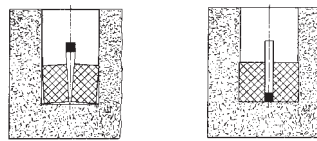

The **EXPANSIONCERT 1** threaded insert consists of a vertically cross-slotted body with a female thread, outer diamond knurls and an expanding plate. On installing the threaded insert in the locating hole, the knurled section is forced apart by downward pressure on the expanding plate and thereby anchored in the wall of the hole.

### Type 0230 EXPANSIONCERT 1 standard

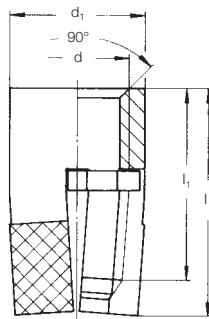

### Location hole<sup>①</sup>

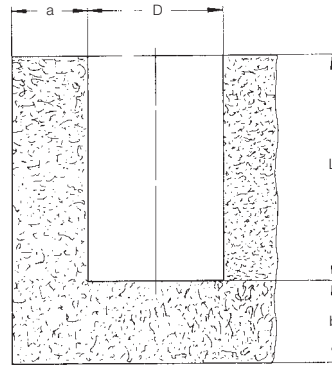

For installation tools and machines, please refer to pages 26–30

d	Article no	d <sub>1</sub>	l	l <sub>1 min.</sub>	D <sup>+0.1</sup>	L	a <sub>min.</sub>	b <sub>min.</sub>
M 2.5	0230 025 0065	4.0	6.5	4.0	4.0	6.5	2.4	3.2
M 3	0230 903 0001	4.0	6.5	4.0	4.0	6.5	2.4	3.2
	0230 003 0065	4.8	6.5	4.0	4.8	6.5	2.9	3.2
M 3.5	0230 035 0008	4.8	8.0	5.0	4.8	8.0	2.9	4.0
	0230 004 0095	5.5	9.5	6.5	5.5	9.5	3.3	4.7
M 4	0230 004 0008	5.5	8.0	5.0	5.5	8.0	3.3	4.0
	0230 005 0011	6.5	11.0	7.5	6.5	11.0	3.9	5.5
M 5	0230 005 0008	6.5	8.0	4.5	6.5	8.0	3.9	4.0
	0230 006 0125	8.0	12.5	8.5	8.0	12.5	4.8	6.2
M 8	0230 008 0016	11.0	16.0	11.0	11.0	16.0	6.6	8.0

Metric ISO threads to DIN 13-6H.  
All rights reserved for technical modifications.  
Minimum quantity on request.

<sup>①</sup> Guide values: dependent on component material. Alter after insertion tests, if necessary.

Other dimensions and specials on request.

**Type 0231<sup>®</sup>**  
**EXPANSIONERT 1** flanged

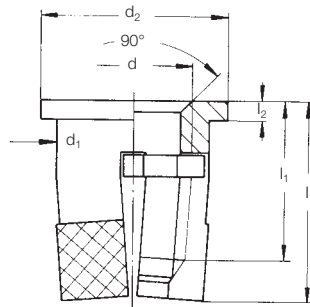

**Location hole<sup>®</sup>**

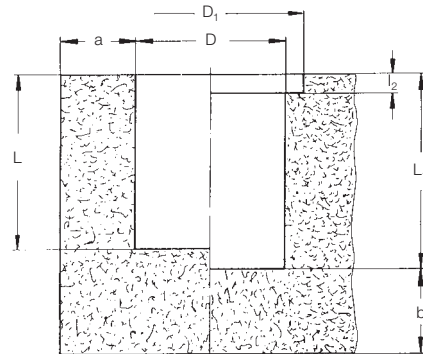

For installation tools, please refer to pages 27-31

d	Article no	l	d <sub>1</sub>	d <sub>2</sub>	l <sub>1 min.</sub>	l <sub>2</sub>	D <sup>+0.1</sup>	D <sub>1</sub> <sup>+0.2</sup>	L	L <sub>1</sub>	a <sub>min.</sub>	b <sub>min.</sub>
M 2.5	0231 025 0006	6.0	4.0	5.5	3.6	0.8	4.0	5.5	5.2	6.0	2.4	3.2
M 3	0231 003 0006	6.0	4.8	6.3	3.5	0.8	4.8	6.3	5.2	6.0	2.9	3.2
M 3.5	0231 035 0075	7.5	4.8	6.3	4.7	0.8	4.8	6.3	6.7	7.5	2.9	4.0
M 4	0231 004 0075	7.5	5.5	7.0	4.4	0.8	5.5	7.0	6.7	7.5	3.3	4.7
M 5	0231 005 0085	8.5	6.5	8.0	5.0	0.8	6.5	8.0	7.7	8.5	3.9	5.5
M 6	0231 006 0011	11.0	8.0	10.0	7.0	0.8	8.0	10.0	10.2	11.0	4.8	6.2

Metric ISO threads to DIN 13-6H.  
Delivery conditions according to DIN 267.  
All rights reserved for technical modifications.  
Minimum quantity on request.  
**Other dimensions and specials on request.**

<sup>®</sup> Guide values: dependent on component material. Alter after insertion tests, if necessary.  
The flange offers a wide support area, thereby reducing surface pressure.

**Type 0232**  
**EXPANSIONERT 1** clinched

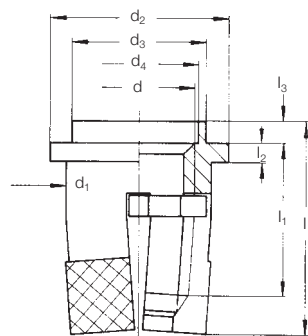

The flared flange is designed for securing contact components and terminal tags and aids fixing of an applied cover.

**Location hole<sup>®</sup>**  
(dimension as type 0231)

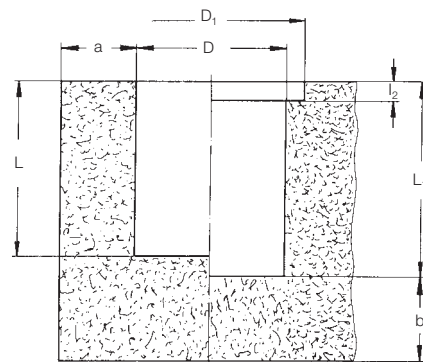

For installation tools, please refer to pages 27-31

d	Article no	l	d <sub>1</sub>	d <sub>2</sub>	d <sub>3 max.</sub>	d <sub>4</sub>	D <sup>+0.1</sup>	D <sub>1</sub> <sup>+0.2</sup>	l <sub>1 min.</sub>	l <sub>2</sub>	l <sub>3</sub>
M 2.5	0232 025 0007	7.0	4.0	5.5	3.6	2.8	4.0	5.5	3.6	0.8	1.0
M 3	0232 003 0007	7.0	4.8	6.3	4.1	3.3	4.8	6.3	3.5	0.8	1.0
M 3.5	0232 035 0085	8.5	4.8	6.3	4.6	3.8	4.8	6.3	4.7	0.8	1.0
M 4	0232 004 0085	8.5	5.5	7.0	5.1	4.3	5.5	7.0	4.4	0.8	1.0
M 5	0232 005 0095	9.5	6.5	8.0	6.1	5.3	6.5	8.0	5.0	0.8	1.0
M 6	0232 006 0012	12.0	8.0	10.0	7.1	6.3	8.0	10.0	7.0	0.8	1.0

Metric ISO threads to DIN 13-6H.  
All rights reserved for technical modifications.  
Minimum quantity on request.

<sup>®</sup> Guide values: dependent on component material. Alter after insertion tests, if necessary.

**Other dimensions and specials on request.**

## EXPANSIONSERT 2



## Advantages

- For reactive resin, PUR, integral hard foam, elastomers and also wood composite materials
  - Wear-resistant thread
  - Rapid, economical installation
- Material: Cu Zn 38 Pb 2

## Principle

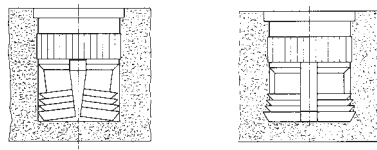

The **EXPANSIONSERT 2** threaded insert consists of a body with a female thread, with a flange and undercuts on the surface. The body has a captive expansion plate, which is forced downwards on installing the threaded insert in the locating hole, thus forcing the lower, slotted section of the **EXPANSIONSERT 2** apart and anchoring its vanes in the wall of the hole. The threaded insert is therefore protected reliably against pull-out and distortion.

Typ 0235

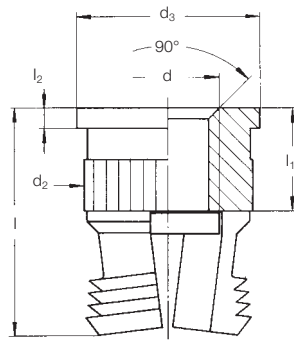

Location hole<sup>①</sup>

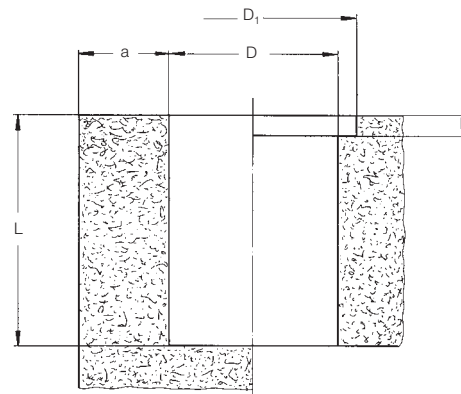

For installation tools and machines, please refer to pages 26–30

d	Article no	l	d <sub>2</sub>	d <sub>3</sub>	l <sub>1</sub>	l <sub>2</sub>	D <sup>+0.1</sup>	D <sub>1</sub>	L <sub>min.</sub>	a <sub>min.</sub>
M 3	0235 103 0008	8.0	5.9	7.0	3.0	0.8	5.5	7.2	8.2	4.0
M 3.5	0235 135 0008	8.0	5.9	7.0	3.5	0.8	5.5	7.2	8.2	4.0
M 4	0235 104 0095	9.5	6.9	8.0	4.0	0.8	6.5	8.2	9.8	5.0
M 5	0235 105 0011	11.0	8.4	10.0	5.0	0.8	8.0	10.2	11.3	6.0
M 6	0235 106 0125	12.5	8.4	10.0	6.0	0.8	8.0	10.2	12.8	6.0

Metric ISO threads to DIN 13-6H.  
All rights reserved for technical modifications.  
Minimum quantity on request.

<sup>①</sup> Guide values: dependent on component material. Alter after insertion tests, if necessary.

Other dimensions and specials on request.

**SPREDSERT® 1**



**Advantages**

- For thermoplastic components
- Knurled flange and anchor rings provide a high degree of safety against distortion and tensile loads
- Screw gripping

Material: Cu Zn 38 Pb 2

**Principle**

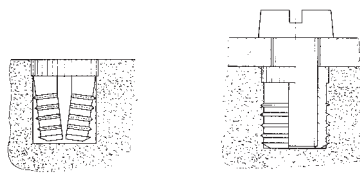

The **SPREDSERT® 1** is inserted into the locating hole until the knurled flange is fully anchored in the plastic. At the same time, the slotted section is forced together. The screw forces the radially secured **SPREDSERT® 1** open causing the anchor rings to bite into the plastic and ensure a firm hold of the threaded insert. Screw locking is also achieved via this process. The tightening torque has to be increased by 10% for the additional expansion force.

Type 0831–0833

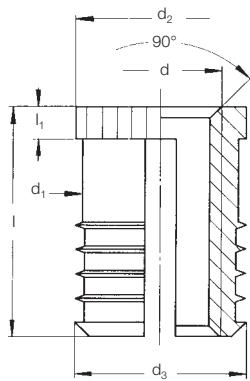

Location hole<sup>Ⓞ</sup>

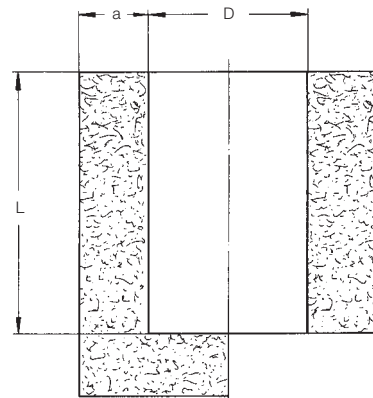

For installation tools and machines, please refer to pages 26–30

d	Article no	No. of anchor rings	d <sub>1</sub>	d <sub>2</sub>	d <sub>3</sub>	l <sup>Ⓞ</sup>	l <sub>1</sub>	D <sup>+0.1</sup>	L <sub>min.</sub>	a <sub>min.</sub>
M 2	0832 102 0004	3	3.15	3.7	3.6	4.0	0.6	3.2	4.5	2.0
M 2.5	0832 125 0005	3	3.9	4.5	4.4	5.0	0.75	4.0	5.5	2.5
M 3	0832 103 0005	3	3.9	4.5	4.4	5.0	0.75	4.0	5.5	3.0
M 3.5	0832 135 0065	3	4.7	5.3	5.2	6.5	1.0	4.8	7.1	3.2
M 4	0833 104 0008	4	5.35	6.0	5.9	8.0	1.3	5.5	8.7	3.5
M 5	0833 105 0095	5	6.35	7.0	6.9	9.5	1.3	6.5	10.3	4.0
M 6	0831 106 0011	5	7.85	8.5	8.4	11.0	2.0	8.0	12.0	5.0
M 8	0831 108 0013	5	9.5	9.95	9.9	13.0	2.0	9.6	14.0	7.0

Metric ISO threads to DIN 13-6H.  
All rights reserved for technical modifications.  
Minimum quantity on request.

<sup>Ⓞ</sup> Guide values: dependent on component material. Alter after insertion tests, if necessary.  
<sup>Ⓞ</sup> Screw contact length = min. length of the insert (l) + 1p (pitch) of thread

Other dimensions and specials on request.

## SPREDSERT® 2



## Advantages

- For thermoset components
- Retaining flange and diamond knurling provide a high degree of safety against distortion and tensile loads
- Screw gripping

Material: Cu Zn 38 Pb 2

## Principle

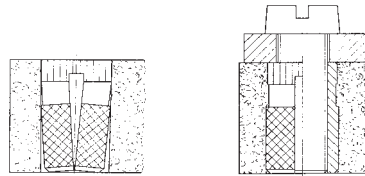

The **SPREDSERT® 2** is inserted into the locating hole until the knurled flange is fully anchored in the plastic. At the same time, the slotted section is forced together. The screw forces the radially secured

**SPREDSERT® 2** open causing the diamond knurling to bite into the plastic and ensure a firm hold of the threaded insert. Screw locking is also achieved via this process. The tightening torque is to be increased by 10% for the additional expansion force.

Type 0837

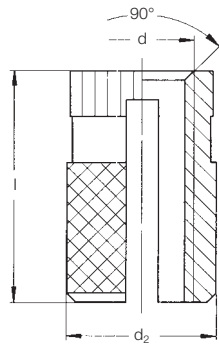

Location hole<sup>①</sup>

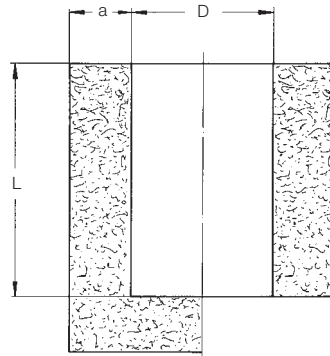

For installation tools and machines, please refer to pages 26–30

d	Article no <sup>②</sup>	l <sup>③</sup>	d <sub>2</sub>	D <sup>+0.1</sup>	L <sub>min.</sub>	a <sub>min.</sub>
M 3	0837 103 0005	5.0	4.3	3.9	5.5	3.0
M 3.5	0837 135 0064	6.4	5.1	4.7	7.0	3.3
M 4	0837 104 0008	8.0	6.0	5.5	8.5	3.5
M 5	0837 105 0095	9.5	6.8	6.3	10.0	4.0
M 6	0837 106 0127	12.7	8.4	7.9	13.5	5.0

Metric ISO threads to DIN 13-6H.  
All rights reserved for technical modifications.

<sup>①</sup> Guide values: dependent on component material. Alter after insertion tests, if necessary.

<sup>②</sup> Minimum quantity on request.

<sup>③</sup> Screw contact length = min. length of the insert (l) + 1p (pitch) of thread

Other dimensions and specials on request.

**SPREDSERT® with retaining flange Advantages**



- For thermoset and thermoplastic components
  - Heavy-duty thread in through holes
  - Screw gripping
- Material: Cu Zn 38 Pb 2

**Principle**

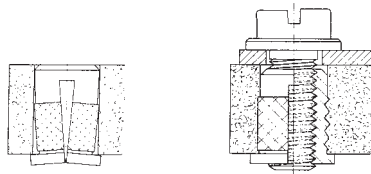

The **SPREDSERT®** with retaining flange is placed in the through hole from the underside until the flange is seated. At this point, the slotted, diamond-knurled anchoring section is compressed. When a screw is inserted, the diamond-knurled section of the threaded insert is forced open and the diamond knurling bites into the plastic. The retaining flange acts as a shoulder and provides a high degree of protection against pull-out. Screw locking is also achieved via this process. The tightening torque is to be increased by 10% for the additional expansion force.

Type 0835

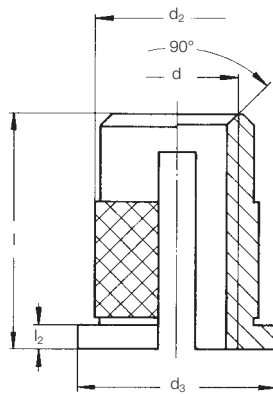

Location hole<sup>①</sup>

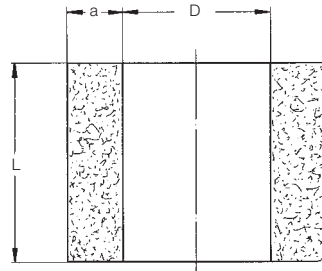

For installation tools and machines, please refer to pages 26–30

d	Article no	l <sup>②</sup>	d <sub>2</sub>	d <sub>3</sub>	l <sub>2</sub>	D <sup>+0.1</sup>	L <sub>min.</sub>	a <sub>min.</sub>
M 3	0835 103 0048	4.8	4.3	5.5	0.5	3.9	4.5	3.2
M 3.5	0835 135 0064	6.4	5.1	6.3	0.7	4.7	6.0	3.6
M 4	0835 104 0008	8.0	6.0	7.0	0.8	5.5	7.5	4.0
M 5	0835 105 0095	9.5	6.8	8.0	1.0	6.3	9.0	4.8
M 6	0835 106 0127	12.7	8.4	9.5	1.3	7.9	12.0	6.0
M 8	0835 108 0127	12.7	9.9	11.0	1.3	9.4	12.0	7.1

Metric ISO threads to DIN 13-6H.  
All rights reserved for technical modifications.  
Minimum quantity on request.

① Guide values: dependent on component material. Alter after insertion tests, if necessary.  
② Screw contact length = min. length of the insert (l) + 1 p (pitch) of thread

Other dimensions and specials on request.

**QUICKSERT® Expansion type 1230**



**Advantages**

- No tapping
- Rapid, economical installation
- Chipping-free installation in smooth location holes
- Stable thread in light alloys
- Stable thread in thermoplastic and thermoset materials\*\* after removal from the mould
- Suitable for one-sided accessibility of the insertion site
- For screw connections to be separated as often as required
- Can be installed in already finished surfaces

Material: 9 SMnPb 28 K, zinc-plated, or Cu Zn 38 Pb 2

**Principle**

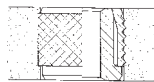

The **QUICKSERT®** expansion insert is spun onto the rotating threaded mandrel of the setting tool and introduced into the locating hole. The latter may be preformed or machined with commercially available drills as a blind or through hole. The axial loading of the threaded mandrel causes the **QUICKSERT®** to shear at the predetermined point between the anchoring sleeve and the threaded section.

The latter is drawn into and expands the anchoring sleeve, forcing the knurls into the hole wall. The threaded insert is now anchored and protected against distortion and pull-out.

Type 1230

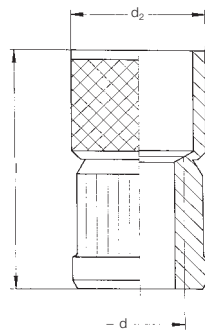

Location hole<sup>①</sup>

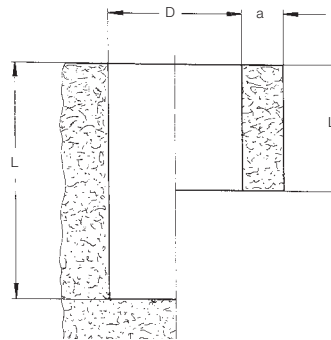

For installation tools and machines, please refer to pages 26–30

d	Steel Article no	Brass Article no	Overall length l	Overall installed length l <sub>1</sub>	Knurl ø d <sub>2</sub>	Location hole			
						øD <sup>+0,1</sup>	L <sub>min</sub>	L <sub>2min</sub>	a*
M3	1230 003 0048	1230 103 0048	8.0	4.8	5.5	5.5	8.8	4.8	2
M4	1230 004 0063	1230 104 0063	10.5	6.3	6.5	6.5	11.8	6.3	2
M5	1230 005 0082	1230 105 0082	13.5	8.2	7.5	7.5	15.2	8.2	2.5
M6	1230 006 0098	1230 106 0098	16.0	9.8	9	9	18.8	9.8	3
M8	1230 008 0 115	1230 108 0 115	19.0	11.5	12	12	21.0	11.5	4

Minimum quantity on request.

Brass threaded inserts are recommended for installation in plastic. Special lengths in addition to special thread diameters and other material on request.

\* Guide values: Increase after insertion tests, if necessary, e.g. for brittle materials.

\*\* This insert is to be specifically checked for suitability for stress crack-susceptible materials (e.g. PC, PPO).

# AMTEC® torque and pull-out values

## Thermal installation

### HITSERT® 2

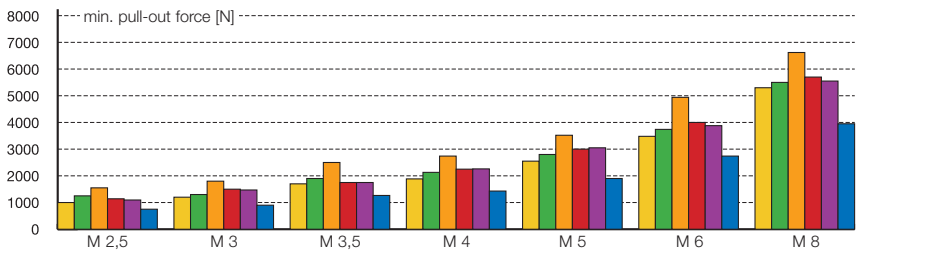
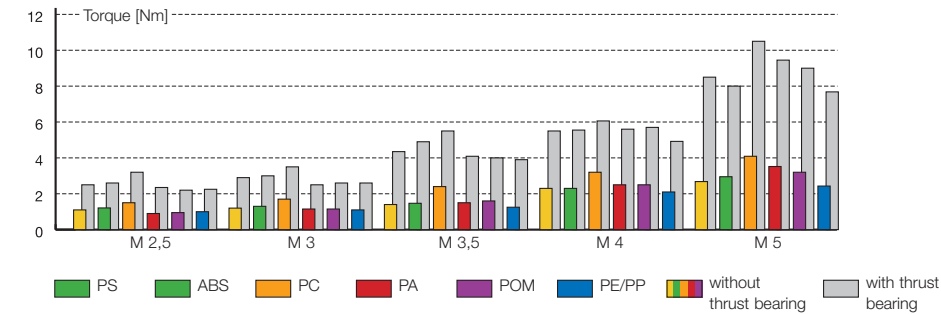

### HITSERT® 2

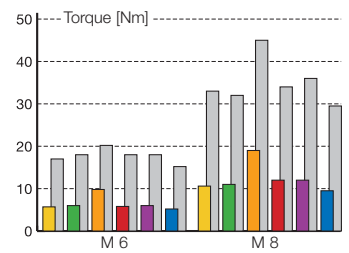

### HITSERT® 3 with M4

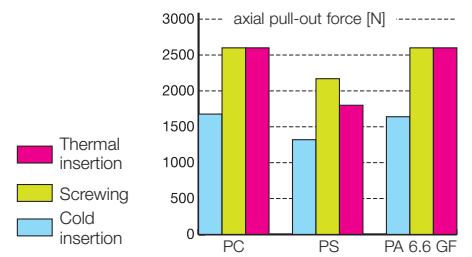

## Ultrasonic installation

### SONICSERT®

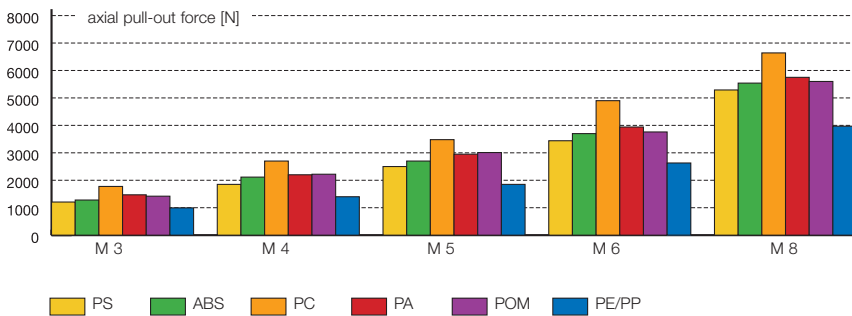

## Expansion anchoring

### EXPANSIONSERT 1

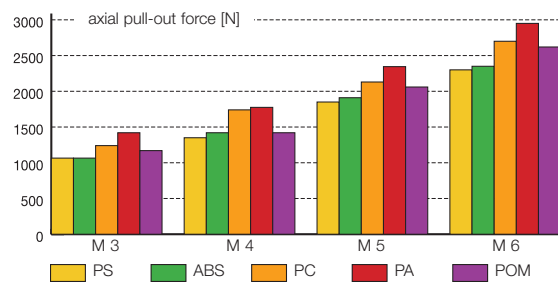

### SPREDSERT®

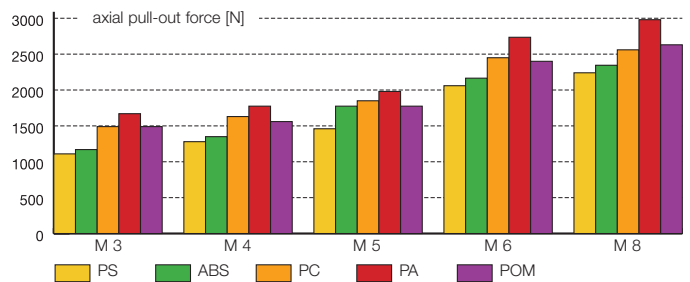

## Self-tapping – installation

### QUICKSERT®

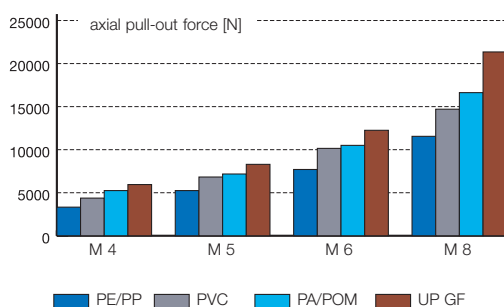

### Technical notes

The stated values are guideline values only. We recommend that an insertion test be performed for the respective application.

In case of fibre-reinforced plastics, the mechanical strength properties of the non-reinforced material should be adopted for safety's sake.

When using brass threaded inserts in stress crack-susceptible plastics (e.g. polycarbonate), we recommend additional surface treatment of the threaded insert (nickel or zinc plating).

Mechanical strength properties for other threaded inserts are available on request.

Customer-specific solutions based on **AMTEC®** threaded inserts



**HITCERT® 2**  
with oval through hole/brass



**HITCERT® 2**  
slotted compression limiter/brass



**QUICKSERT® Expansion**  
expansion insert with flange/steel



**SONICSERT®**  
with fixing hole/brass



**EXPANSIONSERT 1**  
with hexagonal flange/brass



**HITCERT® 2**  
sealing insert with separate  
O-ring/brass



**HITCERT® 3**  
sealing insert  
hose connector/brass

## Installation tools for AMTEC® threaded inserts

### Manual installation tools

#### EXPANSIONSERT 1, EXPANSIONSERT 2, SPREDSERT® 1 and 2

Fitting mandrel for manual installation of **EXPANSIONSERT 1** and **EXPANSIONSERT 2** threaded inserts

	EXPANSIONSERT 1	EXPANSIONSERT 1	EXPANSIONSERT 2	SPREDSERT®
	standard	flange/clinch		
	Article no	Article no	Article no	Article no
M 2.5	0250 025 0065	0253 025 0006	–	0851 125 0000
M 3	0250 003 0065	0253 003 0006	0254 103 0008	0851 103 0000
M 3.5	0250 035 0008	0253 035 0075	–	0851 135 0000
M 4	0250 004 0095	0253 004 0015	0254 104 0095	0851 104 0000
	0250 004 0008	0253 004 0015	0254 104 0095	0851 104 0000
M 5	0250 005 0011	0253 005 0085	0254 105 0011	0851 105 0000
	0250 005 0008	0253 005 0085	0254 105 0011	0851 105 0000
M 6	0250 006 0125	0253 006 0011	0254 106 0125	0851 106 0000
M 8	0250 008 0016	–	–	0851 108 0000



#### QUICKSERT® Expansion type 1230

	Article no
M 5	2353 010 5000
M 6	2353 010 6000
M 8	2353 010 8000



### Semi-automatic tools

#### EXPANSIONSERT 1, EXPANSIONSERT 2

The tool can be incorporated in manual lever presses or other pressing devices

#### QUICKSERT® self-tapping installation, HITSERT® 3

Adaptable to upright drilling machines or cordless screwdrivers

- For small to medium scale production



Example for tool application

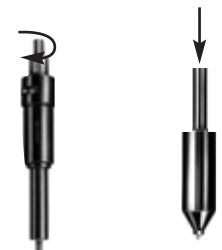

QUICKSERT® EXPANSIONSERT 1, EXPANSIONSERT 2

	EXPANSIONSERT 1	EXPANSIONSERT 1	EXPANSIONSERT 2	QUICKSERT®	Semi-automatic
	standard	flange/clinch		manual installation	
	Article no	Article no	Article no	Article no	Article no
M 2.5	–	0263 025 0006	–	–	–
M 3	0260 003 0065	0263 003 0006	0264 103 0008	1450 010 3000	1460 020 3050
M 3.5	0260 035 5008	0263 035 0075	0264 103 5008	–	–
	0260 004 0095	0263 004 0075	0264 104 0095	1450 010 4000	1460 020 4050
M 4	0260 004 0008	0263 004 0075	0264 104 0095	1450 010 4000	1460 020 4050
	0260 005 0011	0263 005 0085	0264 105 0011	1450 010 5000	1460 020 5050
M 5	0260 005 0008	0263 005 0085	0264 105 0011	1450 010 5000	1460 020 5050
M 6	0260 006 0125	0263 006 0011	0264 106 0125	1450 010 6000	1460 020 6050
M 8	–	–	–	1450 010 8000	1460 020 8050
M 10	–	–	–	1450 011 0000	1460 021 0050

## Installation tools for AMTEC® threaded inserts

### QUICKSERT® expansion anchoring

The setting tool P 2001 allows rapid and secure installation.

- for large scale production

Nominal Ø	Complete tool Article no	Replacement unit Article no
M 3	2361 530 3000	2361 130 3010
M 4	2361 530 4000	2361 130 4010
M 5	2361 530 5000	2361 130 5010
M 6	2361 530 6000	2361 130 6010
M 8	2361 530 8000	2361 130 8010



### QUICKSERT® Hex with flange self-tapping turning, UNIQUICK® Basic telescopic screwdriver system with UNIQUICK® Feeder feeder system

- For large scale production (dimensions on request)



### QUICKSERT® Hex with flange self-tapping turning, UNIQUICK® Vario modular stationary screwdriver system with UNIQUICK® Feeder feeder system

- For large scale production (dimensions on request)



### QUICKSERT® Hex self-tapping turning

Hand mandrel for small-scale production or adaptable to battery-powered screwdriver or pneumatic installation tool (type P-S 1216) for small to medium scale production.

	Article no
M 4	1467 020 5040
M 5	1467 020 5050
M 6	1467 020 5060
M 8	1467 020 5080



### Typ P-S 1216

For quick installation of QUICKSERT® Hex

#### Technical data:

Rotational speed no load:	950 min <sup>-1</sup> at p = 6.3 bar Adjustable with air pressure
Air consumption:	5.5 L/s at p = 6.3 bar
Torque:	M = 1.2 – 5.5 Nm Infinitely adjustable Switch-off clutch
Tool holder:	Quick change chuck ¼" hexagonal DIN 3120 – E 6.3 with radial bearing for installation mandrel
Weight:	0.8 kg
Article no:	65000 4160 180 0010

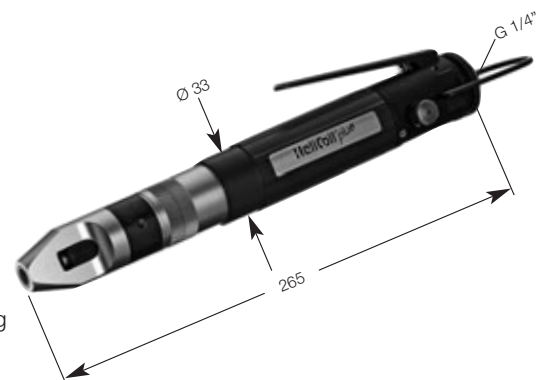

## Installation tools for AMTEC® threaded inserts

### QUICKSERT® self-tapping screwing, plastic in HITSERT® 3 Druckluftschrauber

- High performance by automatic reverse on reaching the preset torque
- Stationary operation by adaptation to parallel guide
- Medium to large scale production

	Complete tool Article no	Replacement unit Article no
M 3	1460 030 3000	1460 030 3050
M 4	1460 030 4000	1460 030 4050
M 5	1460 030 5000	1460 030 5050
M 6	1460 030 6000	1460 030 6050
M 8	1460 030 8000	1460 030 8050
M 10	1460 031 0000	1460 031 0050

Matching parallel guide B 65000 0182 060 0010



### Parallel system type S

Type	Product characteristics		B 65000 Article no
S 600	Working radius	140 mm – 600 mm	0182 080 0003
	Working height	50 mm – 430 mm	
	Weight without tool	8 kg	
	max. permitted torque	Max. 15 Nm	

#### Included in delivery:

- 3-axis guide system
- Tool holder
- 1 balancer 1-3 kg
- Base plate made from extruded aluminium profile with slots, dimensions w x h x l: 240 x 40 x 500 mm

Type	Dimensions	B 65 000 Article no
Maintenance unit	for 6 bar nominal flow G 1/4" = 700 l/min	0182 080 1001
Hose	LW 6	0196 000 1130
Hose clip	8 – 12 mm	0196 000 1150
Hose liner	G 1/8"-6	0196 000 1151
Hose liner	G 1/4"-6	0196 000 1152
Waste air hose	Ø 15 mm	0196 000 1131

#### Advantages

- Ergonomic
- Quick, accurate positioning
- Precise installation direction
- No reaction torque
- Tool holder
- Light and easy to use
- Flexibility
- Suitable for use with electrical and pneumatic installation tools
- Rapid tool changeover
- 360° rotation
- Roller bearings for light, smooth movement
- Save, orderly workstation



**Economical thermal installation of metal threaded inserts (HES)**

suitable for single and multiple installation of **HITSERT® 2**, **HITSERT® 3** and **SONICSERT®**



**Thermal installation of metal threaded inserts by electromagnetic resistance welding (ERW)**

suitable for single and multiple installation of **HITSERT® 2**, **HITSERT® 3** and **SONICSERT®**

especially

- Large volume inserts > M8
- Very small inserts ≤ M2
- Multiple installation



**Ultrasonic installation (USW)**

suitable for **SONICSERT®** up to max. M6



**Friction welding of plastic threaded inserts and screw welded joints (FW)**

suitable for **HITSERT® 2**



## Extended range overview for KVT thermal installation machines for AMTEC® threaded inserts

All machines are suitable for economical processing of **HITSERT® 2**, **HITSERT® 3** and **SONICSERT®**

### Low-cost machines



Manual lever press



Manual installation gun

### High-tech



10-item thermal installation (HES) semi-automatic



Numerically controlled installation machine with automatic feed and threaded insert preheating

## Extended range overview for direct screwing into plastics

### AMTEC® screws

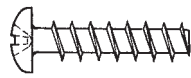

B 52004

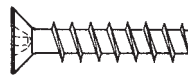

B 52005

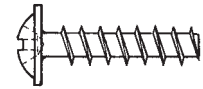

B 52006

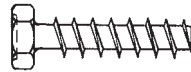

B 52007

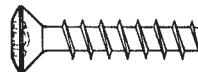

B 52008

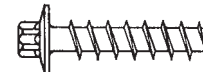

B 52009

#### „in detail“

- Suitable for all thermoplasts (and thermosets).
- The standard version corresponds to mechanical strength class 10.9, other materials and finishes on request.
- Favourable ratio of outer diameter to core diameter, high axial forces.
- Optimum machinability, since screwing torques and overwind torques are wide apart.

#### Tribular cross-section

- Screwing torques are reduced.
- Reserve spaces result in which displaced plastic can flow away without causing damage.

#### Thread pitch

- The thread pitch is adapted in such a way that the pitch angle lies above the self-locking threshold.
- The thread pitch allows broad flank coverage, reduces surface pressure and counteracts **relaxation tendencies** in the plastic.

#### The 30° pitch angle

- Reduces radial stresses and is a prerequisite for construction suited to plastics

B 52004 to B 52006 available dimensions from 2.5 – 6.0 mm, B 52007 to B 52009 on request.

### UNITEC® self-tapping plastic screws

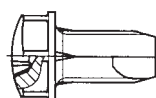

K' in K'

A firm, self-locking joint for plastic components can be created using this plastic screw. Material, shape and dimensions on request. Further information is available in our brochure 4330.

### The system concept

Behind the brand name **AMTEC**<sup>®</sup> direct screw connections lies not just another self-tapping screw for plastic materials, but a complete system solution from a single supplier:

- A highly efficient screw, specially adapted to the conditions specific to plastic structures.
- Competent advice in terms of application technology.
- Screw insertion tests tailored to the customer in order to determine the requisite parameters for serial manufacture.
- An optimum screw system, tailored to the customer's wishes (including process monitoring).

### Installation system for direct screwing of plastics

#### Hand-held screw driving system

##### **UNIQUICK**<sup>®</sup> Basic: The quick screwdriver

- Compact and robust structure
- For harsh industrial environments
- Rod or pistol design



##### **UNIQUICK**<sup>®</sup> Mini: The handy screwdriver

- Automation of small screw joints
- Small, handy screwdriver
- Easy to use
- Pneumatic or electric drive



##### **UNIQUICK**<sup>®</sup> Advance: The ergonomic screwdriver

- Easy to find, join and turn the screw
- Protects the surface of the component during the screw fastening process
- Shortens installation time
- Pneumatic or electric drive



#### Stationary screw driving system

##### **UNIQUICK**<sup>®</sup> Vario: The stationary screw driving unit

- Automated or fully automated production
- Compact and narrow construction
- Standardised design in 3 sizes
- Short cycle times
- Pneumatic or electric drive



#### Feeding technology

##### **UNIQUICK**<sup>®</sup> Feeder: The vibratory conveyor

- Plastic sorter pan
- Quiet and gentle conveyor (protects surfaces)
- Modular structure
- Few format-dependent parts
- Maximum reliability and maintenance free
- Separation up to four screws



<b>Customer data</b>	Date of inquiry: _____	
	Company: _____ Adress: _____ _____	
	Tel.: _____ Fax: _____ E-Mail: _____	
	Contact person (name and responsibilities): _____ _____	
	applicable department: _____	
	Customer's authorisation guidelines: _____	
Requested date for visit from technical marketing manager: _____		
<b>Application</b>	Technical description (function, dimensions, tolerances, etc.)	
	Can Böllhoff – be supplied with a sample (according to application)? <input type="checkbox"/> yes <input type="checkbox"/> no – be supplied with a drawing (of the application)? <input type="checkbox"/> yes <input type="checkbox"/> no	
	Manufacturing and tooling principle: _____	
	Enclosures: _____	
<b>Commercial information</b>	New application: <input type="checkbox"/> yes <input type="checkbox"/> no	Prototypes required <input type="checkbox"/> yes <input type="checkbox"/> no
	Annual requirement: _____	if yes, date and quantity: _____
	Quantity supplied: _____	Initial sample required: <input type="checkbox"/> yes <input type="checkbox"/> no
	Duration of application: _____	if yes, date and quantity: _____
	Start of volume production (date): _____	Preliminary series required: <input type="checkbox"/> yes <input type="checkbox"/> no
		if yes, date and quantity: _____
Current solution (to this or a similar application):		
Technical problem areas:		





# Böllhoff International

## North Europe

Wilhelm Böllhoff GmbH & Co. KG, Bielefeld  
Böllhoff GmbH, Bielefeld with branches  
in Bielefeld, Braunschweig, Dormagen,  
Leipzig, Munich, Nuremberg and Stuttgart,  
Böllhoff Verbindungstechnik GmbH, Bielefeld  
Böllhoff Systemtechnik GmbH & Co. KG, Bielefeld,  
Böllhoff Schraubtechnik GmbH, Bielefeld  
Böllhoff Produktion GmbH & Co. KG, Bielefeld  
and Sonnewalde, Germany  
Bollhoff Fastenings Ltd., Birmingham, Great Britain

## South-West Europe

Bollhoff Oталu s. a., La Ravoire, France  
Bollhoff s.r.l., Mailand, Italy  
Bollhoff s.a., Madrid, Spain

## South-East Europe

Böllhoff GmbH, Linz, Austria  
Böllhoff Kft, Székesfehérvár, Hungary  
Böllhoff s. r. o., Prag, Czech-Republic  
Böllhoff s.r.l., Bors, Romania  
Bimex-Böllhoff, Krzemienica,  
Bollhoff Technika Łączenia Sp. z o.o., Wrocław, Poland  
Böllhoff OOO, Velikij Novgorod, Russia  
Böllhoff Civata Ticaret Limited Sirketi, Istanbul, Turkey

## North America

Bollhoff RIVNUT® Inc., Kendallville, Indiana, USA  
Bollhoff Inc., Ontario, Canada  
Bollhoff S.A. de C.V., Mexico City, Mexico

## South America

Bollhoff Adm. e Part. Ltda., Jundiaí,  
Bollhoff Service Center Ltda., Jundiaí,  
Porto Alegre and Curitiba, Brazil  
Bollhoff S.A., Buenos Aires, Argentina

## Africa

Bollhoff (Pty) Ltd., Centurion, South Africa

## Asia

Bollhoff Fastenings Ltd., Wuxi, China

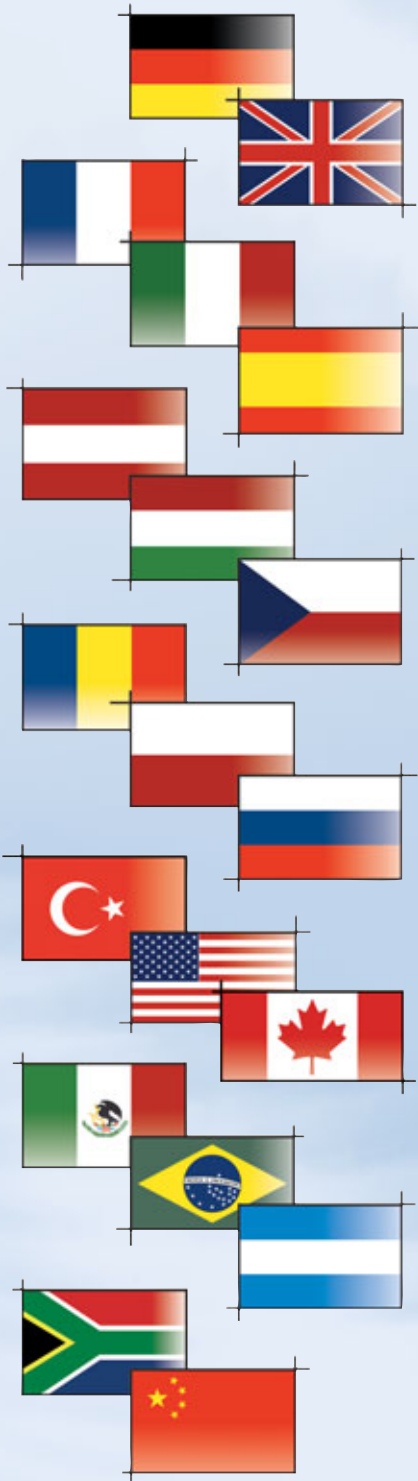

**TECHNOLOGY COMPONENTS  
SOUTHWEST**

817-923-2900

[sales@technologycomponents.com](mailto:sales@technologycomponents.com)  
[www.technologycomponents.com](http://www.technologycomponents.com)

In addition to Böllhoff companies in these 19 countries, the company has a network of agents and dealers serving an international customer base in major industrial markets world-wide.

# BÖLLHOFF

Böllhoff Verbindungstechnik GmbH · Archimedesstraße 1-4 · 33649 Bielefeld · Germany  
Phone +49 (0)5 21 / 44 82-05 (3 26) · Fax - 6 58 · Internet [www.boellhoff.com](http://www.boellhoff.com) · E-Mail [fasteningtechnology@boellhoff.com](mailto:fasteningtechnology@boellhoff.com)

